

FEATURES

- Up to 7 V Supply Voltage
- Configurable Phase Multiplier as Doubler from A Single PWM Input
- Capable of Generating High Output Switching Frequency from 200 kHz to 2000 kHz
- Tri-State PWM Input for Power Stage Shutdown
- Small Size: DFN2x2-8L Package
- Operating Ambient Temperature Range of -40°C to 125°C

APPLICATIONS

Desktop Computers
Data Center

GENERAL DESCRIPTION

The **HP1800** is a phase multiplier which is designed to double the phase count from a controller.

The **HP1800** is capable of driving two independent power stages from a single PWM input. The input PWM signal is internally split to drive two power stages 180° out of phase, each at half of the PWM input frequency.

The **HP1800** is available in DFN-8L package, 2 mm x 2 mm body size.

TYPICAL APPLICATION CIRCUIT

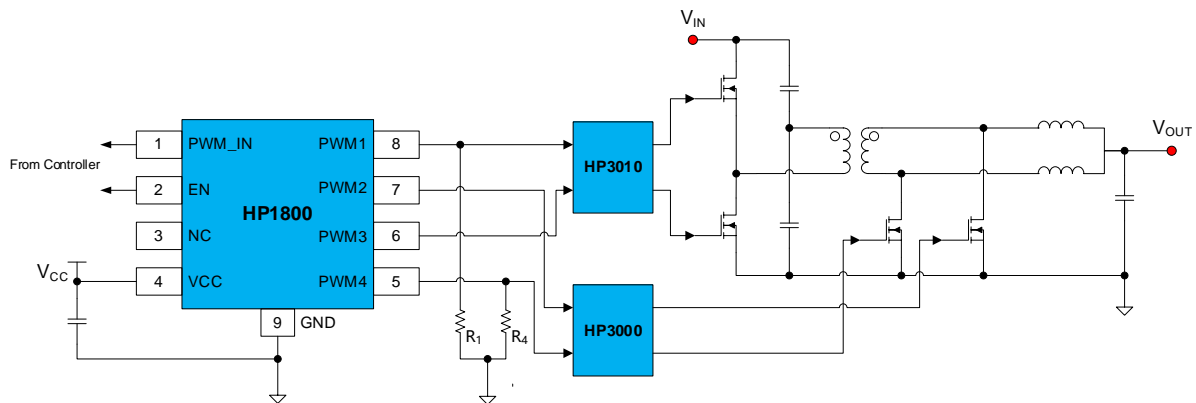

Figure 1 Typical Application Circuit

TABLE OF CONTENTS

Features1

Applications1

General Description1

Typical Application Circuit1

Table of Contents2

Revision History2

Pin Configuration and Function Descriptions3

Specifications4

Absolute Maximum Ratings6

 Thermal Resistance6

 ESD Caution6

Typical Performance Characteristics7

Theory of Operation11

 Overview11

 Input/Output PWM Signals11

 DT Initialization12

Typical Application Circuits15

Package Outline Dimensions16

Package Top Marking17

Ordering Guide18

Tape And Reel Information19

Important Notice20

REVISION HISTORY

Version	Date	Descriptions
Rev. 1.0	08/14/2025	Initial version
Rev. 1.1	12/2025	Added details of PWM timing. Updated tri-state window in electrical specification.

PIN CONFIGURATION AND FUNCTION DESCRIPTIONS

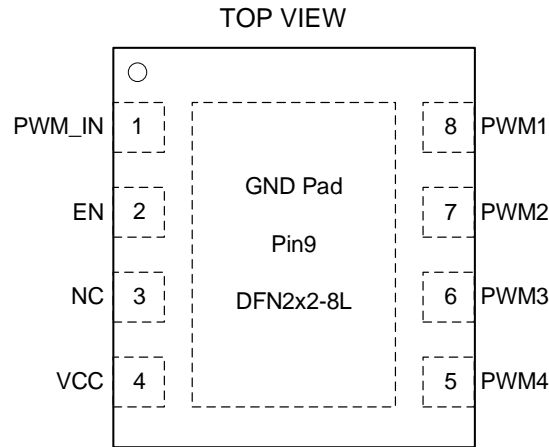

Figure 2 HP1800-AA000-DN08R Pin Assignment

Table 1. Pin Function Descriptions for HP1800-AA000-DN08R

Pin No.	Name	Function
1	PWM_IN	The PWM_IN is the control signal input. Connect this pin to the PWM output of the controller.
2	EN	Enable output PWM. This pin asserted LOW disables PWM output. This pin biased high enables all output PWM.
3	NC	No connection. It must be left unconnected.
4	VCC	Supply voltage.
5	PWM4	PWM4 signal to the power stage (Initialize the rising edge dead time).
6	PWM3	PWM3 signal to the power stage.
7	PWM2	PWM2 signal to the power stage.
8	PWM1	PWM1 signal to the power stage (Initialize the falling edge dead time).
9	GND	Reference ground. All signals are referenced to this node.

SPECIFICATIONS

VCC = 5 V to 7 V, TA = -40°C to +125°C, unless otherwise specified.

Table 2. Specifications

Parameter	Symbol	Conditions	Min	Typ	Max	Unit
VCC						
Supply Voltage			5		7	V
Supply Current	V _{ICC}	V _{CC} = 5 V, C _{PWM} = 50 pF, PWM_IN = 1 MHz, Duty = 50%; R _{PWM1/4} = 3.3 kΩ; R _{PWM2/3} = open			4	mA
UVLO Vcc Rising	V _{UVLO_R}		3.6	4.1	4.5	V
UVLO Vcc Falling	V _{UVLO_F}	PWM1/2/3/4 output voltage < 0.8 V	3.3	3.8	4.3	V
UVLO Hysteresis			0.1	0.3	0.5	V
UVLO Vcc Falling Delay		Measured from V _{CC} falling < 3.6 V to PWM1 < 0.8 V			1	μs
EN						
EN Input High Threshold	V _{EN_H}		2.4			V
EN Input Low Threshold	V _{EN_L}				0.8	V
Internal Pull-up Resistance	R _{PULLUP_EN}		10		300	kΩ
EN Floating Voltage	V _{EN_F}	V _{CC} = 5 V to 7 V	2.7		3.4	V
Enable Power-on Delay	t _{EN_on_delay}	Measured from EN rising edge to PWM1 > 1 V			5	μs
Enable Power-off Delay	t _{EN_off_delay}	Measured from EN falling edge to PWM1 < 1 V			0.2	μs
PWM_IN						
PWM Voltage	V _{PWM_OP}		0		3.3	V
PWM Input High Threshold	V _{IH}	PWM low or Tri-state to high	2.6			V
PWM Input Low Threshold	V _{IL}	PWM high or Tri-state to low			0.75	V
Transition Time-Rise		Measured from 0.4 V to 2.9 V			15	ns
Transition Time-Fall		Measured from 2.9 V to 0.4 V			15	ns
Tri-state Window	V _{PWM_S}		1.2		1.95	V
PWM Hysteresis	V _{PWM_HYS}	Active to Tri-state or Tri-state to Active	1	40	120	mV
PWM Input Tri-State Floating Voltage	V _{PWM_TRI}		1.4	1.6	1.8	V
Internal Pull-up Resistance			3.3	10	20	kΩ
Internal Pull-down Resistance			3.3	10	20	kΩ
Frequency of The PWM Input	f _{sw}		0.2		2.0	MHz
Recognized PWM Pulse Width		T _{PRD} is the period of PWM_IN input signal	40		T _{PRD} - 40	ns
PWM1, PWM2, PWM3, PWM4						
PWM Output High Threshold	V _{OH(PWM)}	Load resistance to GND ≥ 3.3 kΩ	2.9	3.15	V _{CC} + 0.3	V
PWM Output Low Threshold	V _{OL(PWM)}				0.4	V
Transition Time-Rise	T _{R(HS)}	C _{PWM} = 50 pF, R _{PWM} = 3.3 kΩ, Measured from 0.4 V to 2.9 V			15	ns
Transition Time-Fall	T _{F(HS)}	C _{PWM} = 50 pF, measured from 2.9 V to 0.4 V			15	ns

Parameter	Symbol	Conditions	Min	Typ	Max	Unit
Propagation Delay-Enter Tri-State	$T_{PDTS(en)}$	Measured from the edge PWM_IN enters tri-state to PWM2/PWM 4 low			70	ns
Minimum Output Pulse Width	T_{MinPWM}				40	ns
Initialization Time		V_{CC} rises to PWM output time. PWM output low level before initialization finish			2	ms
PWM1 Voltage Before Initialization		Connect with 150 k Ω to GND			0.8	V
PWM2 Voltage Before Initialization		Floating			0.8	V
PWM3 Voltage Before Initialization		Floating			0.8	V
PWM4 Voltage Before Initialization		Connect with 150 k Ω to GND			0.8	V

ABSOLUTE MAXIMUM RATINGS

Table 3. Absolute maximum ratings

Parameter	Rating
Supply voltage, VCC	-0.3 V to 8 V
PWM_IN, PWM1, PWM2, PWM3, PWM4, EN	-0.3 V to VCC + 0.3 V
Operating temperature range (Ambient)	-40 to +125°C
Operating temperature range (Junction)	-40 to +150°C
Storage temperature range	-55 to +150°C
Soldering conditions	JEDEC J-STD-020
Electrostatic Discharge (ESD)	
Human body model	±4000 V
Charged device model	±2000 V

Stresses at or above those listed under Absolute Maximum Ratings may cause permanent damage to the product. This is a stress rating only; functional operation of the product at these or any other conditions above those indicated in the operational section of this specification is not implied. Operation beyond the maximum operating conditions for extending periods may affect product reliability.

THERMAL RESISTANCE

Thermal performance is directly linked to print circuit board (PCB) design and operating environment. Close attention to PCB thermal design is required.

θ_{JA} is the natural convection junction to ambient thermal resistance measured in a one cubic foot sealed enclosure.

θ_{JC} is the junction to case thermal resistance.

Table 4. Thermal Resistance

Package Type	θ_{JA}	θ_{JC}	Unit
DFN2x2-8L	111.5	73.2	°C/W

ESD CAUTION



Electrostatic Discharge Sensitive Device.

Charged devices and circuit boards can discharge without detection. Although this product features patented or proprietary protection circuitry, damage may occur on devices subjected to high energy ESD. Therefore, proper ESD precautions should be taken to avoid performance degradation or loss of functionality.

TYPICAL PERFORMANCE CHARACTERISTICS

V_{CC} = 5 V. T_A = -40°C to +125°C, unless otherwise specified.

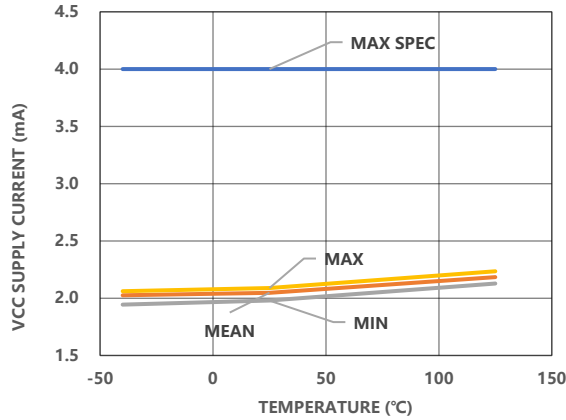

Figure 3 VCC Supply Current vs. Temperature

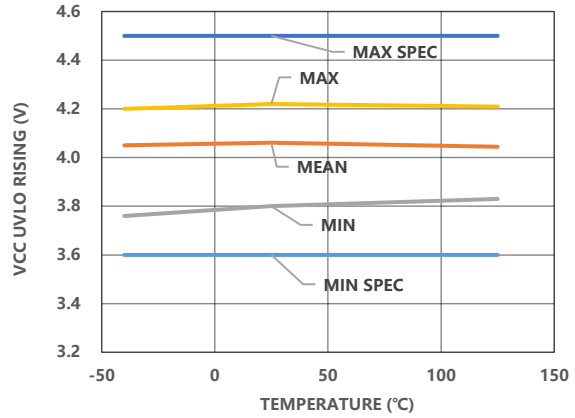

Figure 4 VCC UVLO Rising vs. Temperature

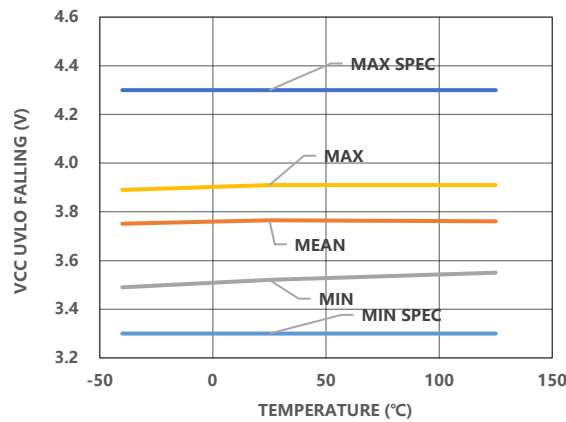

Figure 5 VCC UVLO Falling vs. Temperature

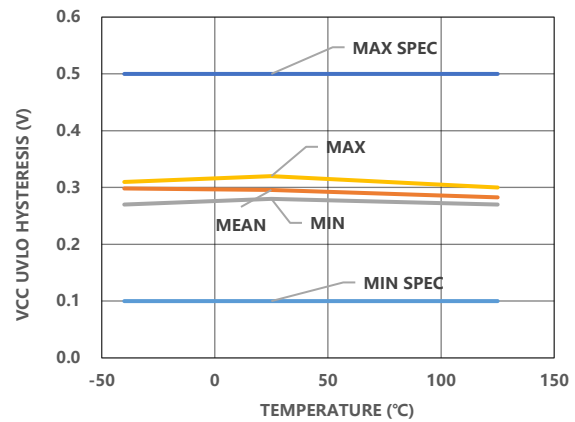

Figure 6 VCC UVLO Hysteresis vs. Temperature

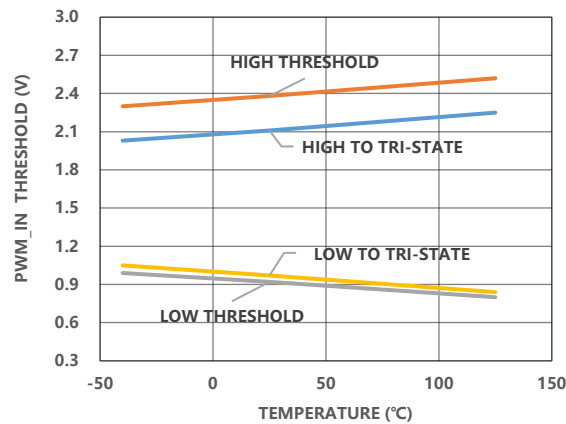

Figure 7 PWM_IN Threshold vs. Temperature

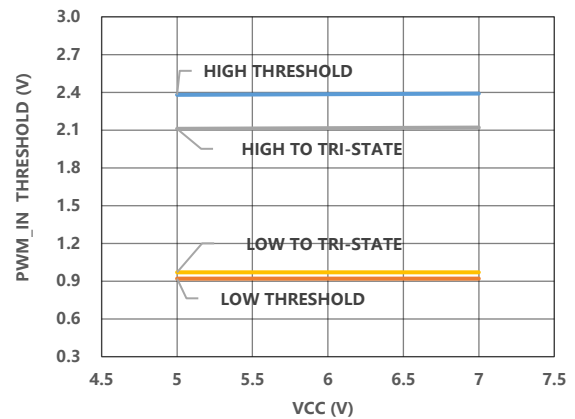

Figure 8 PWM_IN Threshold vs. VCC

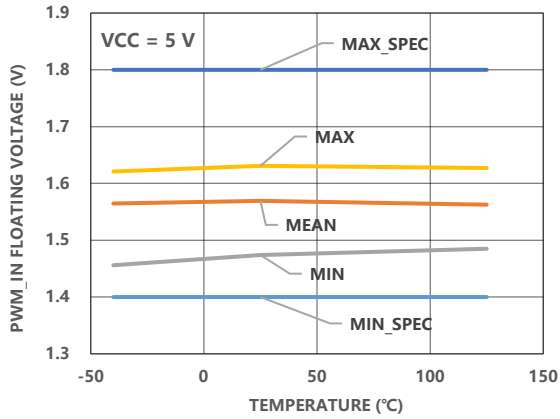

Figure 9 PWM_IN Floating Voltage vs. Temperature, VCC = 5 V

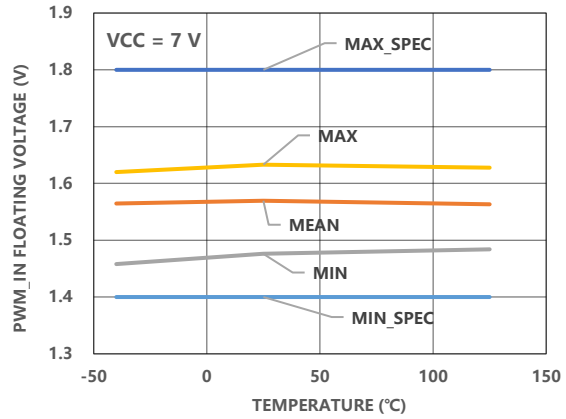

Figure 10 PWM_IN Floating Voltage vs. Temperature, VCC = 7 V

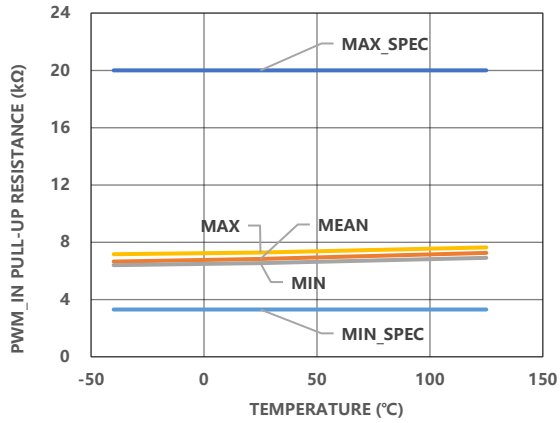

Figure 11 PWM_IN Pull-up Resistance vs. Temperature

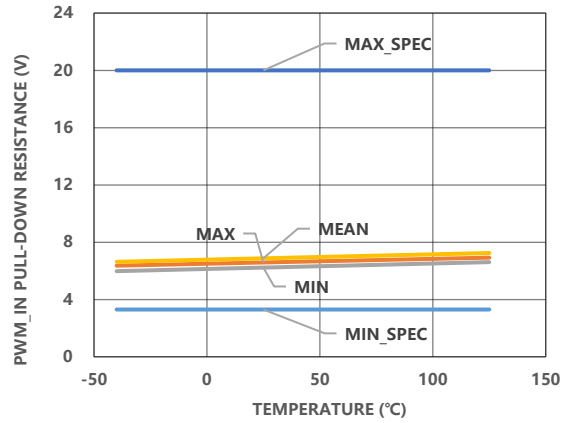

Figure 12 PWM_IN Pull-down Resistance vs. Temperature

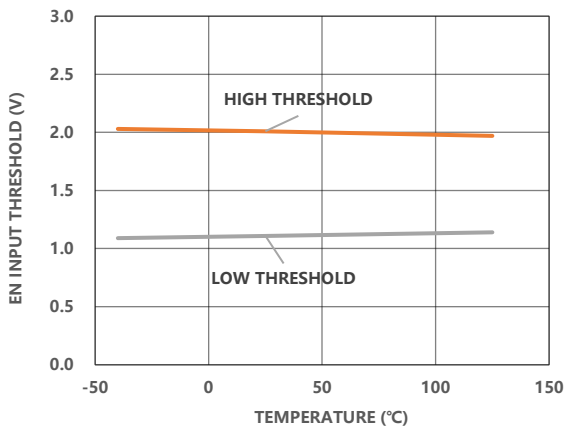

Figure 13 EN Input Threshold vs. Temperature

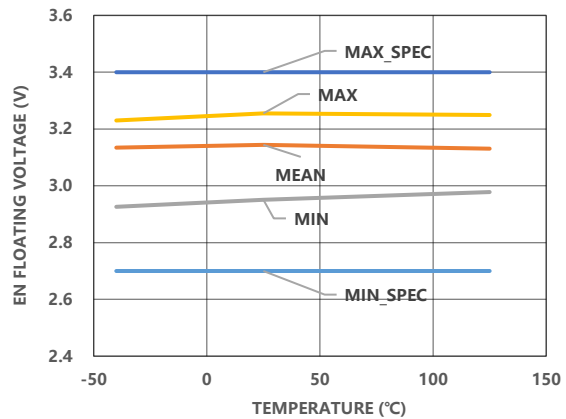

Figure 14 EN Floating Voltage vs. Temperature

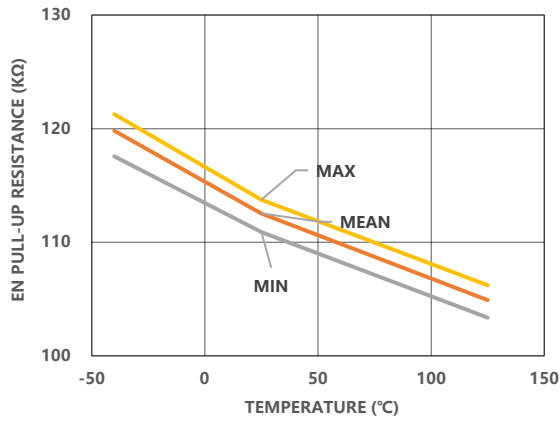

Figure 15 EN Pull-up Resistance vs. Temperature

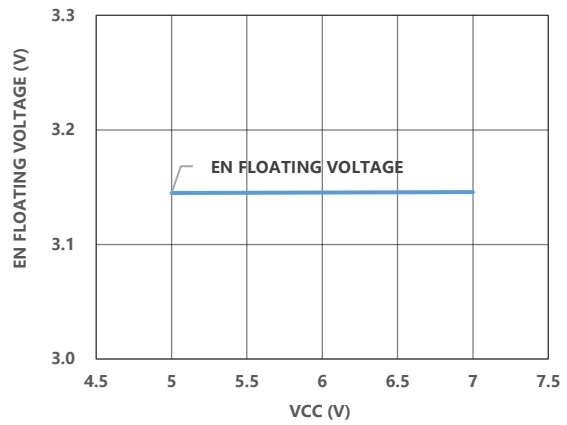

Figure 16 EN Floating Voltage vs. VCC

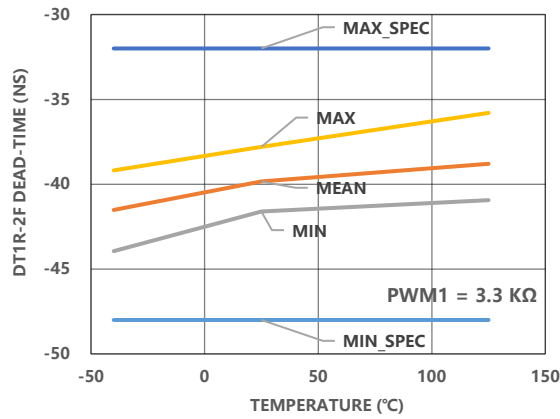

Figure 17 DT1R-2F Initial Dead-Time vs. Temperature, 3.3 kΩ Pull-down Resistor on the PWM1 (IR)

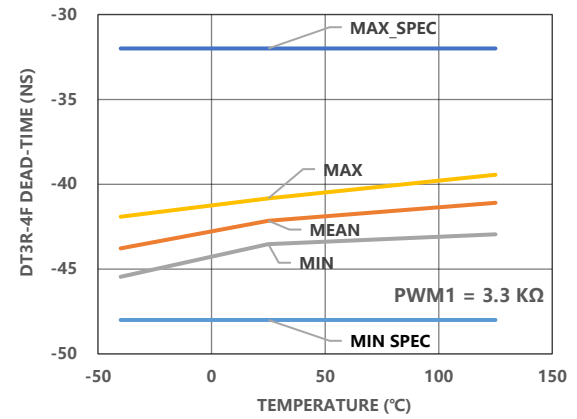

Figure 18 DT3R-4F Initial Dead-Time vs. Temperature, 3.3 kΩ Pull-down Resistor on the PWM1 (IR)

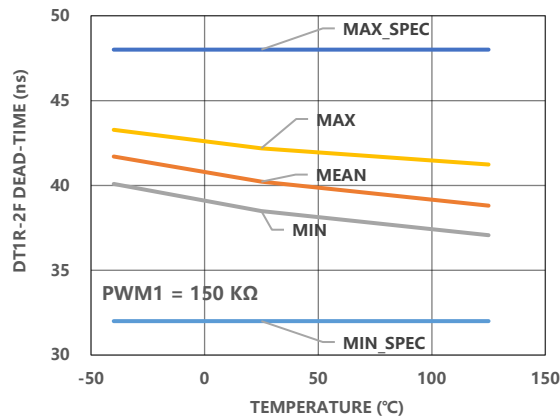

Figure 19 DT1R-2F Initial Dead-Time vs. Temperature, 150 kΩ Pull-down Resistor on the PWM1 (IR)

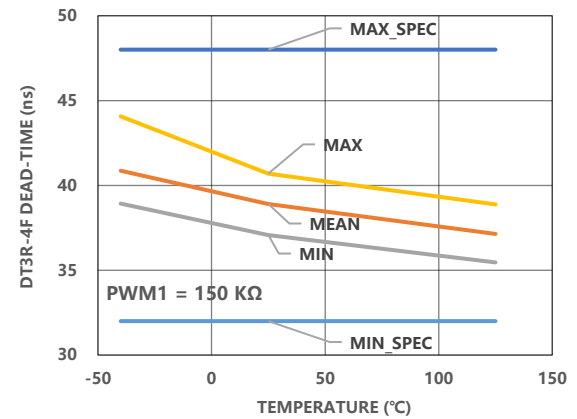

Figure 20 DT3R-4F Initial Dead-Time vs. Temperature, 150 kΩ Pull-down Resistor on the PWM1 (IR)

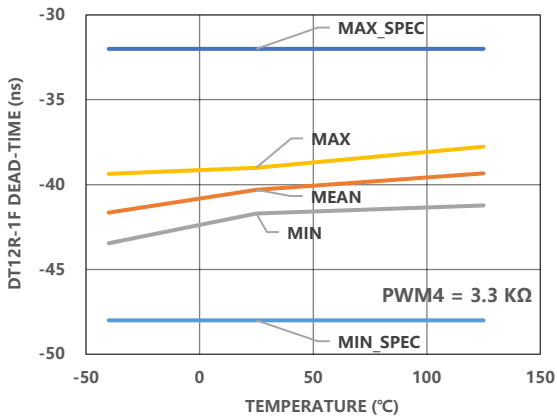

Figure 21 DT2R-1F Initial Dead-Time vs. Temperature, 3.3 kΩ Pull-down Resistor on the PWM4 (IF)

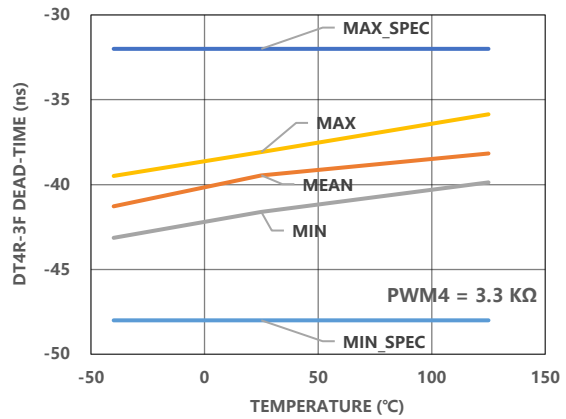

Figure 22 DT4R-3F Initial Dead-Time vs. Temperature, 3.3 kΩ Pull-down Resistor on the PWM4 (IF)

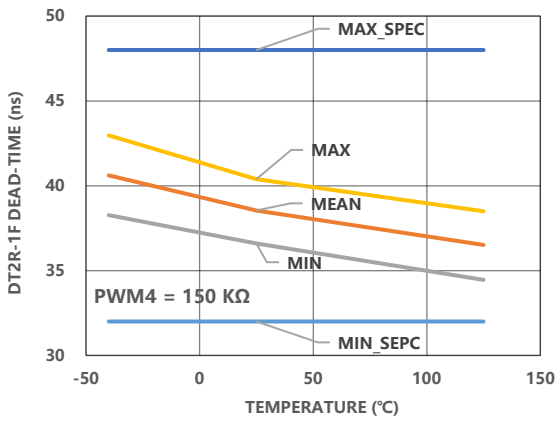

Figure 23 DT2R-1F Initial Dead-Time vs. Temperature, 150 kΩ Pull-down Resistor on the PWM4 (IF)

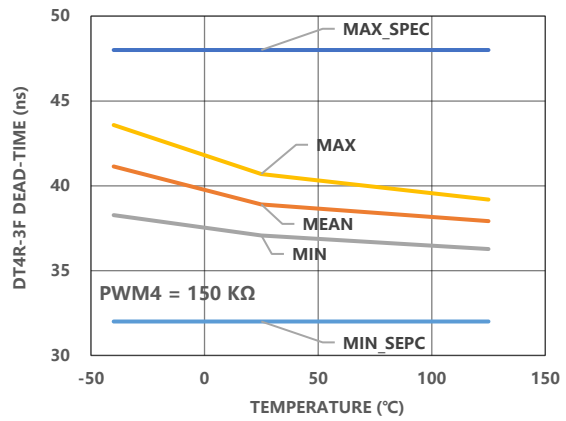

Figure 24 DT4R-3F Initial Dead-Time vs. Temperature, 150 kΩ Pull-down Resistor on the PWM4 (IF)

THEORY OF OPERATION

OVERVIEW

The HP1800 is a phase multiplier IC designed to enhance multi-phase power systems by generating two complementary PWM pairs from a single PWM input, effectively doubling phase count. Targeting high-efficiency applications like desktop PCs and data centers, it integrates seamlessly with controllers, drivers, or power stages, enabling scalable power delivery.

Its compact DFN2x2-8L package, wide voltage range (5 V to 7 V), and industrial-grade temperature tolerance (-40°C to +125°C) ensure robust performance in space-constrained, high-density designs, bridging controller flexibility with power-stage optimization for next-generation computing infrastructure.

INPUT/OUTPUT PWM SIGNALS

The external PWM input is connected to PWM_IN. The internal partial frequency circuit generates two PWM channels, which are output through PWM1 and PWM3. Another two additional PWM channels are generated and output at PWM2 and PWM4. PWM2 provides the complementary signal to PWM1, and PWM4 provides the complementary signal to PWM3. When PWM_IN is within Tri-State window, the HP1800 enters a Tri-State condition and the signals including PWM1, PWM2, PWM3 and PWM4 are driven to a low level.

PWM_IN must initiate a complete pulse on the PWM outputs before resuming normal operation from Tri-State condition as shown in Figure 25 and Figure 26. Prior to this initiation, the PWM output remains at a low level. It is crucial to avoid PWM output errors that may arise from incorrect dead-time configurations.

In the output sequence, PWM1 starts outputting first, followed by PWM3.

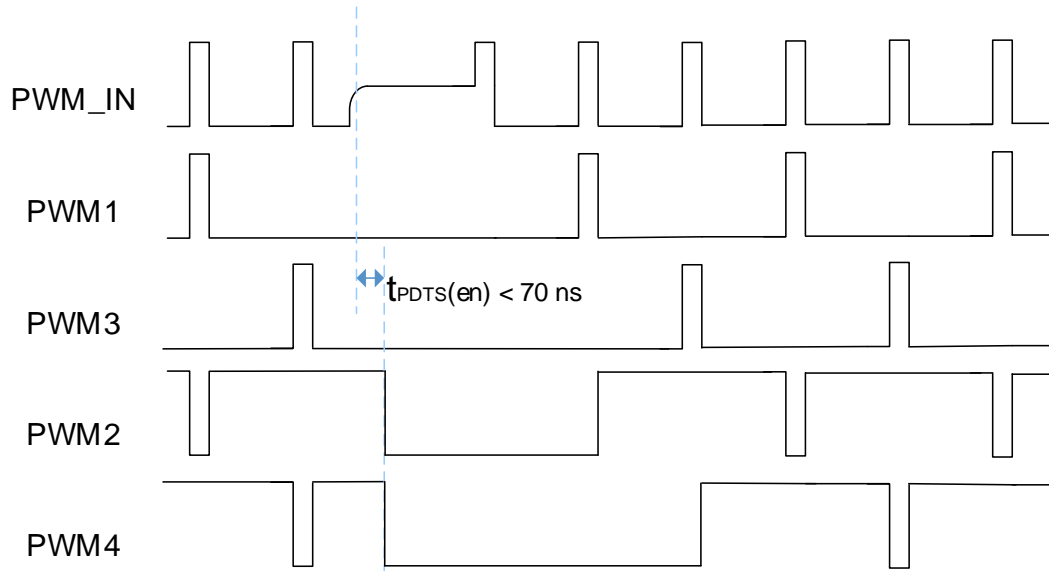

Figure 25 PWM Entering Tri-state Mode (a)

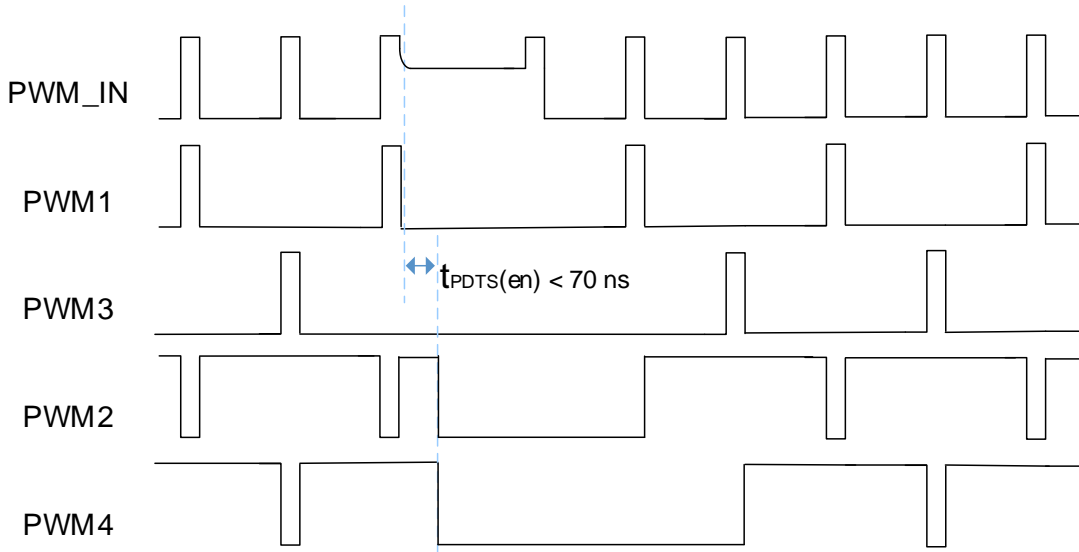

Figure 26 PWM Entering Tri-state Mode (b)

DT INITIALIZATION

The pull-down resistors on PWM1 and PWM4 determine the initial dead-time. Refer to the tables below for resistor-value-to-dead-time mappings. The delay time from PWM_IN to rising/falling edges of PWMx (x = 1 to 4) are defined as Figure 27 shown.

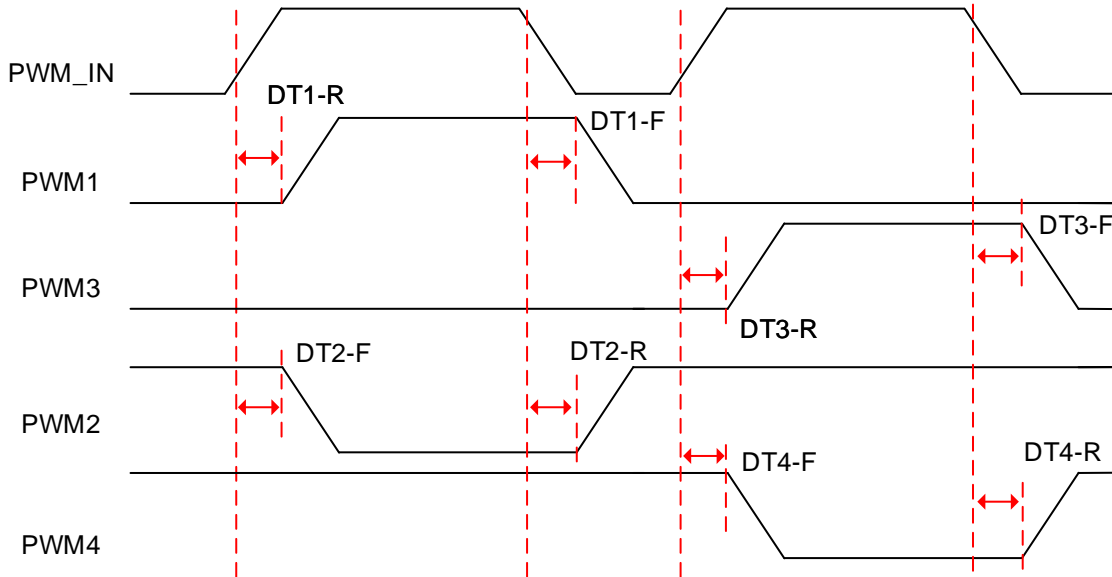

Figure 27 Timing Diagram of Dead Time

Table 5 PWM1 Pull Down Resistor

Resistor (kΩ)	DT1-R (ns)	DT3-R (ns)	DT2-F (ns)	DT4-F (ns)
3.3	40	40	80	80
4.7	44	44	76	76
6.8	48	48	72	72
10	52	52	68	68
15	56	56	64	64
22	60	60	60	60

33	64	64	56	56
47	68	68	52	52
68	72	72	48	48
100	76	76	44	44
150	80	80	40	40

Table 6 PWM4 Pull Down Resistor

Resistor (k Ω)	DT1-F (ns)	DT3-F (ns)	DT2-R (ns)	DT4-R (ns)
3.3	80	80	40	40
4.7	76	76	44	44
6.8	72	72	48	48
10	68	68	52	52
15	64	64	56	56
22	60	60	60	60
33	56	56	64	64
47	52	52	68	68
68	48	48	72	72
100	44	44	76	76
150	40	40	80	80

Table 9 DT Accuracy PWM1 (-40 to +125°C)

PWM1(IR) Resistor setting (k Ω)	Min	Typ	Max	Unit
3.3 (DT1-R) - (DT2-F)	-48	-40	-32	ns
4.7 (DT1-R) - (DT2-F)	-40	-32	-24	ns
6.8 (DT1-R) - (DT2-F)	-32	-24	-16	ns
10 (DT1-R) - (DT2-F)	-24	-16	-8	ns
15 (DT1-R) - (DT2-F)	-16	-8	0	ns
22 (DT1-R) - (DT2-F)	-8	0	8	ns
33 (DT1-R) - (DT2-F)	0	8	16	ns
47 (DT1-R) - (DT2-F)	8	16	24	ns
68 (DT1-R) - (DT2-F)	16	24	32	ns
100 (DT1-R) - (DT2-F)	24	32	40	ns
150 (DT1-R) - (DT2-F)	32	40	48	ns
3.3 (DT3-R) - (DT4-F)	-48	-40	-32	ns
4.7 (DT3-R) - (DT4-F)	-40	-32	-24	ns
6.8 (DT3-R) - (DT4-F)	-32	-24	-16	ns
10 (DT3-R) - (DT4-F)	-24	-16	-8	ns
15 (DT3-R) - (DT4-F)	-16	-8	0	ns
22 (DT3-R) - (DT4-F)	-8	0	8	ns
33 (DT3-R) - (DT4-F)	0	8	16	ns
47 (DT3-R) - (DT4-F)	8	16	24	ns
68 (DT3-R) - (DT4-F)	16	24	32	ns

100	(DT3-R) - (DT4-F)	24	32	40	ns
150	(DT3-R) - (DT4-F)	32	40	48	ns

Table 10 DT Accuracy PWM4 (-40 to +125°C)

PWM4(IF) Resistor setting (kΩ)		Min	Typ	Max	Unit
3.3	(DT2-R) - (DT1-F)	-48	-40	-32	ns
4.7	(DT2-R) - (DT1-F)	-40	-32	-24	ns
6.8	(DT2-R) - (DT1-F)	-32	-24	-16	ns
10	(DT2-R) - (DT1-F)	-24	-16	-8	ns
15	(DT2-R) - (DT1-F)	-16	-8	0	ns
22	(DT2-R) - (DT1-F)	-8	0	8	ns
33	(DT2-R) - (DT1-F)	0	8	16	ns
47	(DT2-R) - (DT1-F)	8	16	24	ns
68	(DT2-R) - (DT1-F)	16	24	32	ns
100	(DT2-R) - (DT1-F)	24	32	40	ns
150	(DT2-R) - (DT1-F)	32	40	48	ns
3.3	(DT4-R) - (DT3-F)	-48	-40	-32	ns
4.7	(DT4-R) - (DT3-F)	-40	-32	-24	ns
6.8	(DT4-R) - (DT3-F)	-32	-24	-16	ns
10	(DT4-R) - (DT3-F)	-24	-16	-8	ns
15	(DT4-R) - (DT3-F)	-16	-8	0	ns
22	(DT4-R) - (DT3-F)	-8	0	8	ns
33	(DT4-R) - (DT3-F)	0	8	16	ns
47	(DT4-R) - (DT3-F)	8	16	24	ns
68	(DT4-R) - (DT3-F)	16	24	32	ns
100	(DT4-R) - (DT3-F)	24	32	40	ns
150	(DT4-R) - (DT3-F)	32	40	48	ns

TYPICAL APPLICATION CIRCUITS

Figure 28 demonstrates a typical application circuit of the HP1800 for driving an interleaved half-bridge current doubler converter. This converter steps down the input voltage from typically 48 V to 1.2 V using only single power stage, increasing the power conversion efficiency comparing to two stage conversion. PWM_IN and EN are controlled by an external multi-phase controller. The PWM1-PWM4 outputs drive both the half-bridge driver HP3010 (120 V/ 3 A) and the dual-channel low-side driver HP3000 (30 V/ 5 A). Initial dead times between complementary pairs (PWM1/PWM2 and PWM3/PWM4) are independently configured via resistors R₁ at PWM1 and R₄ at PWM4.

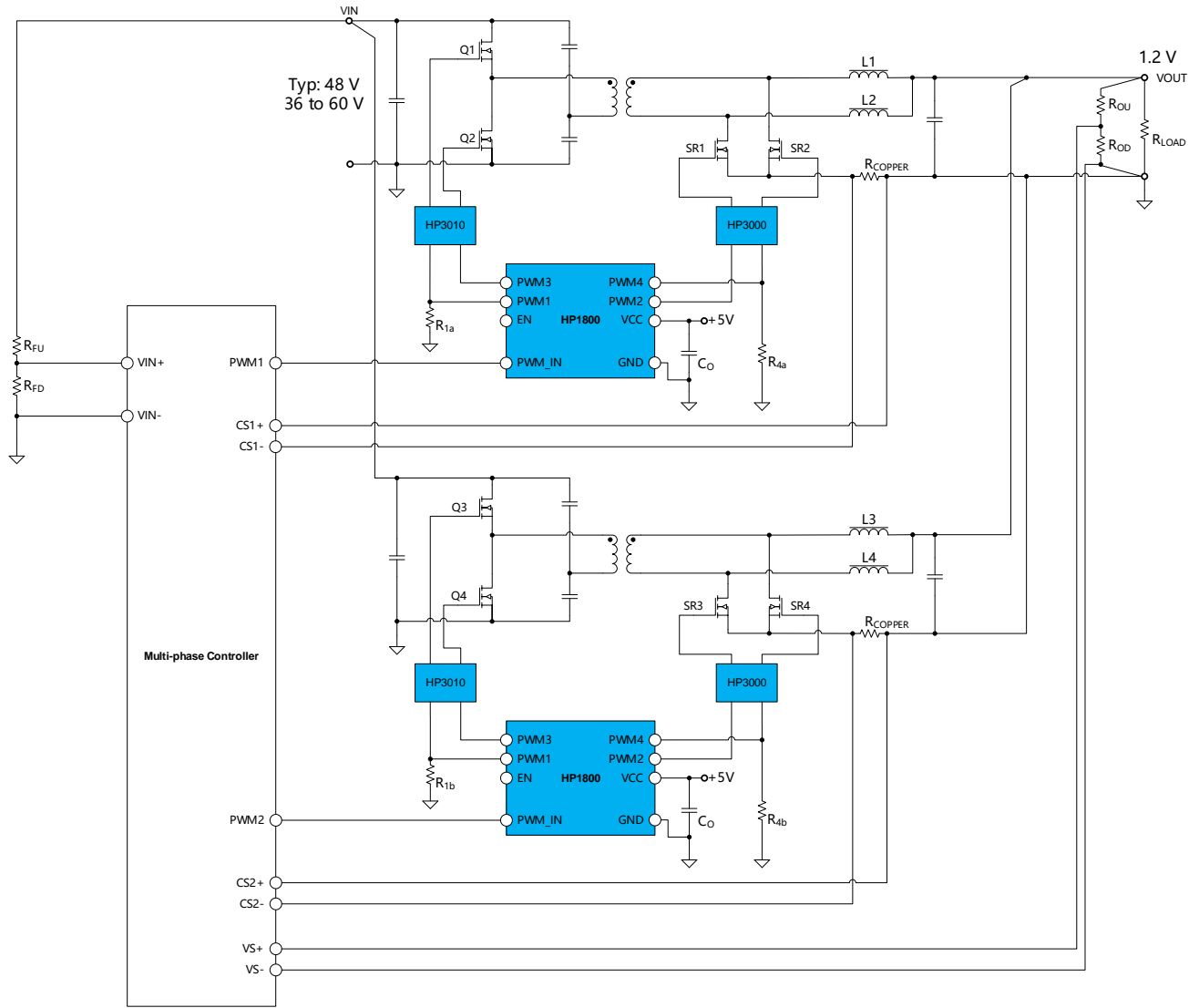
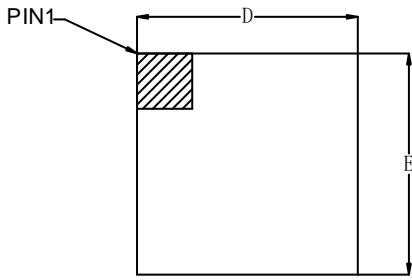
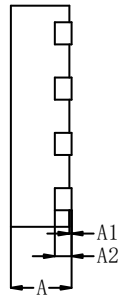

Figure 28 Typical Application Circuit

PACKAGE OUTLINE DIMENSIONS



TOP VIEW



SIDE VIEW

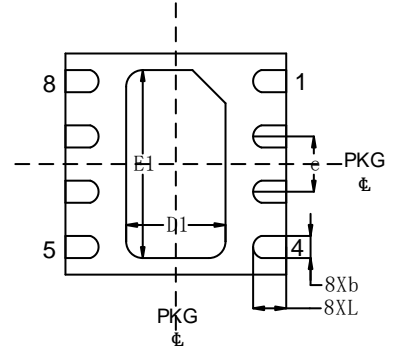

SYMBOLS	DIMENSION IN MILLIMETERS		
	MIN	NOM	MAX
A	0.50	0.55	0.60
A1	0.00	0.02	0.05
A2	0.152 REF		
b	0.15	0.20	0.25
D	2 BSC		
E	2 BSC		
e	0.5 BSC		
L	0.25	0.30	0.35
D1	0.80	0.90	1.00
E1	1.60	1.70	1.80

Figure 29 HP1800-AA000-DN08R Dimensions

PACKAGE TOP MARKING

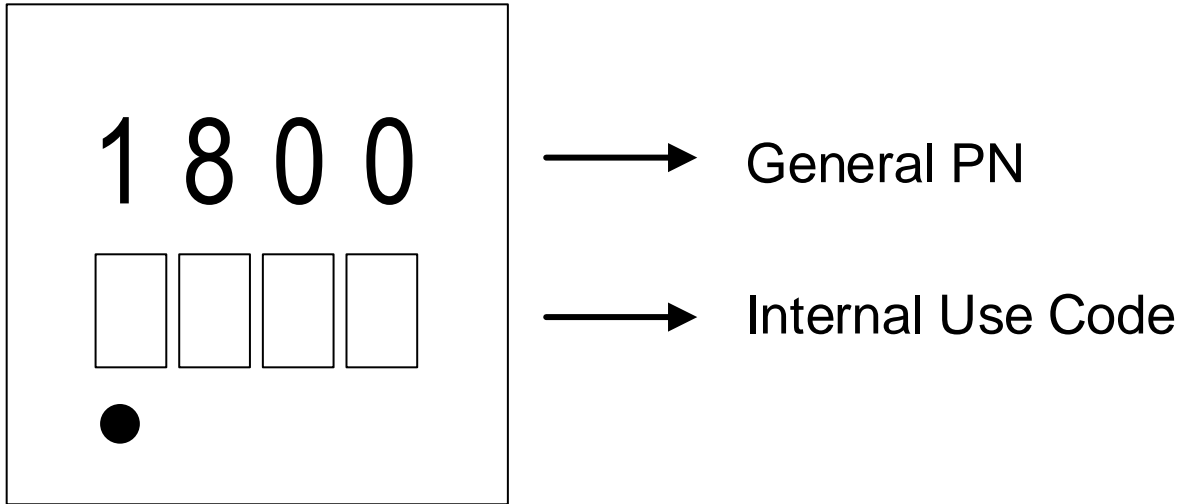
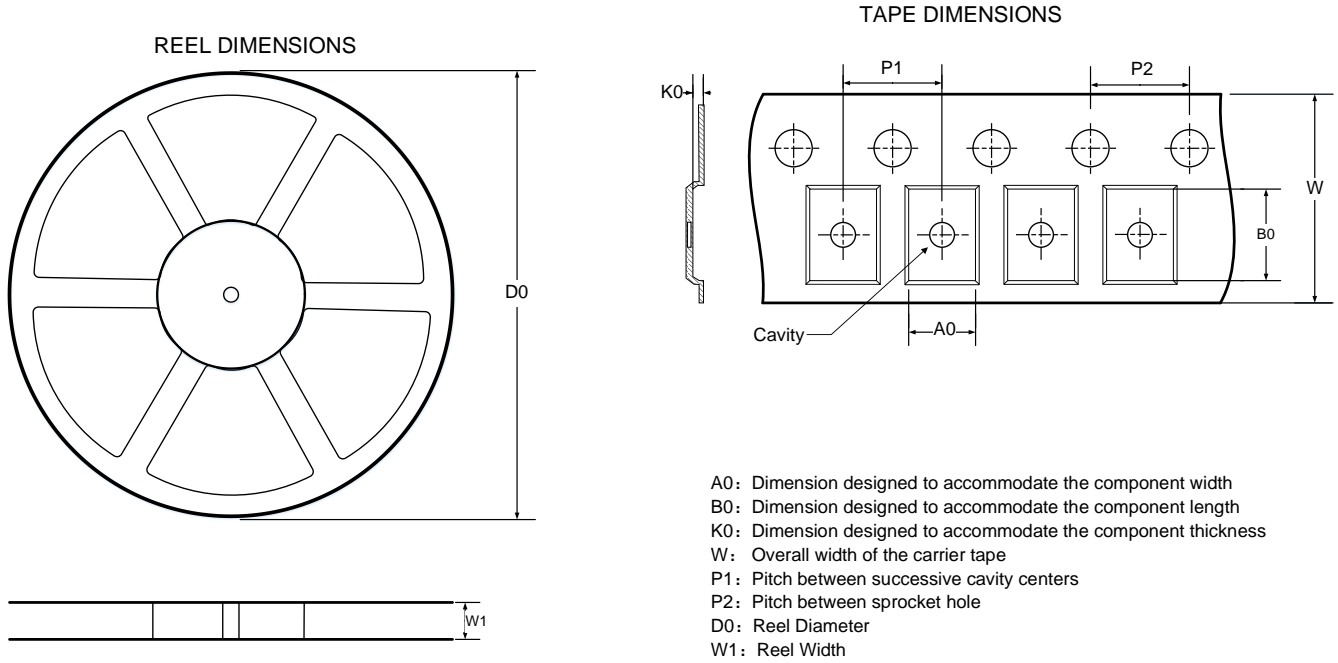

Figure 30 HP1800-AA000-DN08R Package Top Marking

ORDERING GUIDE

Model	Temperature Range	Package Type	MSL	Package Option	Quantity
HP1800-AA000-DN08R	-40°C to +125°C	DFN2x2-8L	1	T&R	4000

TAPE AND REEL INFORMATION



QUADRANT ASSIGNMENTS FOR PIN 1 ORIENTATION IN TAPE

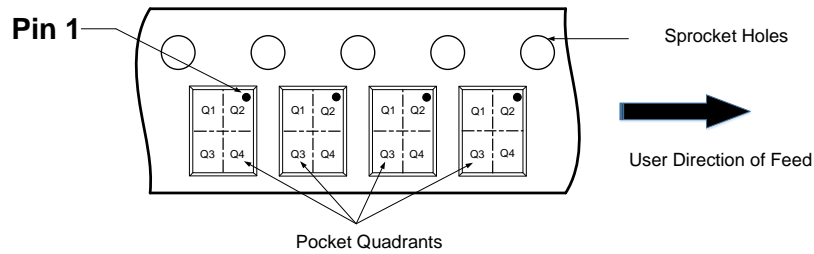

DIMENSIONS AND PIN1 ORIENTATION

D0 (mm)	W1 (mm)	A0 (mm)	B0 (mm)	K0 (mm)	P1 (mm)	P2 (mm)	W (mm)	Pin1 Quadrant
180.00	9.50	2.20	2.20	0.75	4.00	4.00	8.00	Q2

All dimensions are nominal

Figure 31 Tape and Reel Information

IMPORTANT NOTICE

Oriental Semiconductor Co., Ltd. and its subsidiaries (Orientalsemi) reserve the right to make corrections, enhancements, improvements and other changes to its semiconductor products and services per JESD46, latest issue, and to discontinue any product or service per JESD48, latest issue. Buyers should obtain the latest relevant information before placing orders and should verify that such information is current and complete. All semiconductor products (also referred to herein as "components") are sold subject to Orientalsemi's terms and conditions of sale supplied at the time of order acknowledgment.

Orientalsemi warrants performance of its components to the specifications applicable at the time of sale, in accordance with the warranty in Orientalsemi's terms and conditions of sale of semiconductor products. Testing and other quality control techniques are used to the extent Orientalsemi deems necessary to support this warranty. Except where mandated by applicable law, testing of all parameters of each component is not necessarily performed.

Orientalsemi assumes no liability for applications assistance or the design of Buyers' products. Buyers are responsible for their products and applications using Orientalsemi components. To minimize the risks associated with Buyers' products and applications, Buyers should provide adequate design and operating safeguards.

Orientalsemi does not warrant or represent that any license, either express or implied, is granted under any patent right, copyright, mask work right, or other intellectual property right relating to any combination, machine, or process in which Orientalsemi components or services are used. Information published by Orientalsemi regarding third-party products or services does not constitute a license to use such products or services or a warranty or endorsement thereof. Use of such information may require a license from a third party under the patents or other intellectual property of the third party, or a license from Orientalsemi under the patents or other intellectual property of Orientalsemi.

Reproduction of significant portions of Orientalsemi information in Orientalsemi data books or data sheets is permissible only if reproduction is without alteration and is accompanied by all associated warranties, conditions, limitations, and notices. Orientalsemi is not responsible or liable for such altered documentation. Information of third parties may be subject to additional restrictions.

Resale of Orientalsemi components or services with statements different from or beyond the parameters stated by Orientalsemi for that component or service voids all express and any implied warranties for the associated in Orientalsemi component or service and is an unfair and deceptive business practice.

Orientalsemi is not responsible or liable for any such statements.

Buyer acknowledges and agrees that it is solely responsible for compliance with all legal, regulatory and safety-related requirements concerning its products, and any use of Orientalsemi components in its applications, notwithstanding any applications-related information or support that may be provided by Orientalsemi. Buyer represents and agrees that it has all the necessary expertise to create and implement safeguards which anticipate dangerous consequences of failures, monitor failures and their consequences, lessen the likelihood of failures that might cause harm and take appropriate remedial actions. Buyer will fully indemnify Orientalsemi and its representatives against any damages arising out of the use of any Orientalsemi components in safety-critical applications.

In some cases, Orientalsemi components may be promoted specifically to facilitate safety-related applications. With such components, Orientalsemi's goal is to help enable customers to design and create their own end-product solutions that meet applicable functional safety standards and requirements. Nonetheless, such components are subject to these terms.

No Orientalsemi components are authorized for use in FDA Class III (or similar life-critical medical equipment) unless authorized officers of the parties have executed a special agreement specifically governing such use.

Only those Orientalsemi components which Orientalsemi has specifically designated as military grade or "enhanced plastic" are designed and intended for use in military/aerospace applications or environments. Buyer acknowledges and agrees that any military or aerospace use of Orientalsemi components which have not been so designated is solely at the Buyer's risk, and that Buyer is solely responsible for compliance with all legal and regulatory requirements in connection with such use.

Orientalsemi has specifically designated certain components as meeting ISO/TS16949 requirements, mainly for automotive use. In any case of use of non-designated products, Orientalsemi will not be responsible for any failure to meet ISO/TS16949.

Please refer to below URL for other products and solutions of Oriental Semiconductor Co., Ltd.